



**SUBMITAL AND DRAWING
MODEL-DD**

PROJECT :
 ENGINEER :
 CONTRACTOR :
 SUBMITTED BY :
 DATE :

INDUSTRIAL /LOUVER-DIFFUSER

MATERIAL : Aluminum frame and drum
 FACE : Side wall/Ceiling

DRUM DIFFUSER

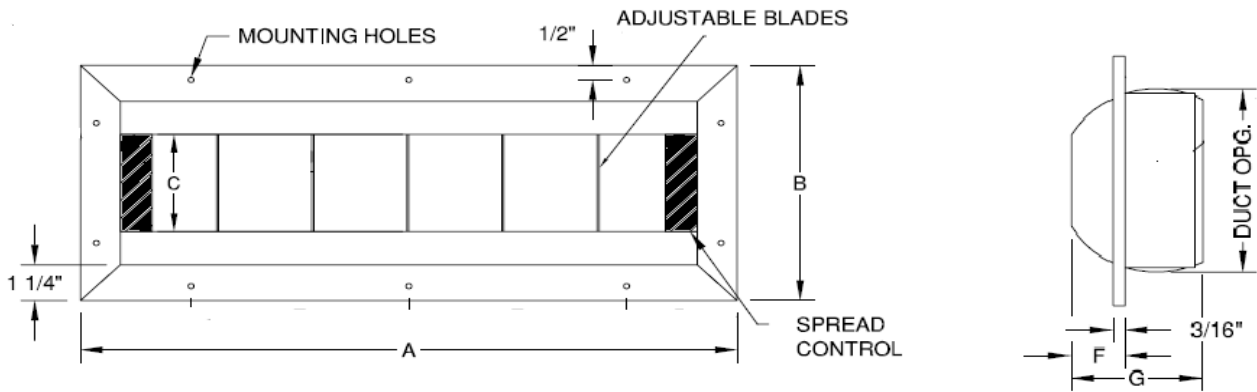

AVAILABLE SIZES :

Height	B	C	F	G
6	8 -3/16"	3 -1/16"	1 10/16"	3" -6/8"
10	12 -1/2"	5 -7/8"	2 13/16"	5-7/8"
12	14 -13/16"	7 -5/8"	2 13/16"	5-7/8"
15	17 -1/8"	10" -5/8"	2 13/16"	5-7/8"

A 18" TO 72" (1" INCREMENTS)

BLADE TYPE

Single Blade

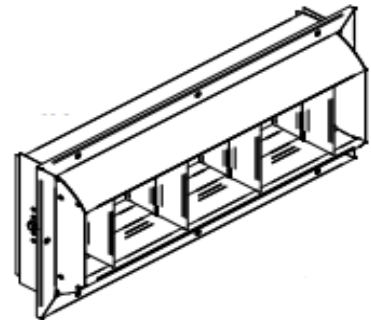

OPTIONS:

- DD-AS : Air Scoop Option (AS)
- DD-M : Actuator / Motorized Option (M)

DAMPER OPTIONS:

- 00-WD- NO DAMPER
- DL-MD- MULTI SHUTTER DAMPER
- DL-OBDD : Opposed Blade Damper Option (OBD)

Split Blade

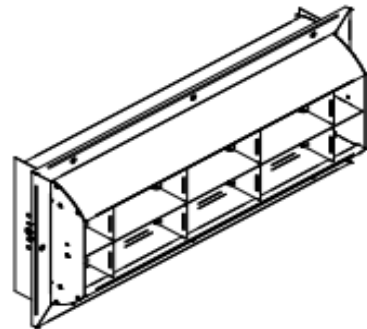

AVAILABLE FINISHES

STANDART FINISH

01 WHITE (RAL 9010)

OPTIONAL FINISH (NO EXTRA CHARGE):

06 MILL FINISH 02 WHITE (RAL 9016)

OPTIONAL FINISH (ADDITIONAL CHARGE):

03 SILVER-Ral9006 07 CUSTOM COLOR/ SET UP CHARGE
 04 ANODIZED 08 RAL...../SET UP CHARGE
 05 BLACK-Ral9005

As part of our continuous improvement program, we reserve the right to make further improvements without notice.